

C-325NC

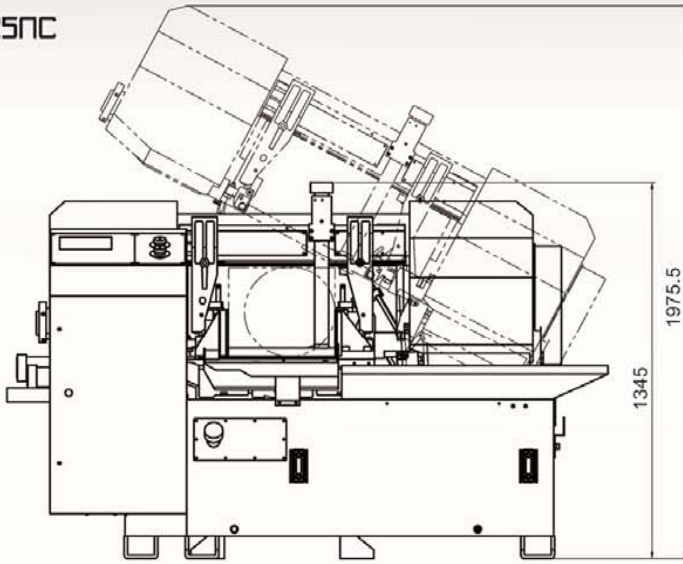

Horizontal
Numerical Control
Automatic Bandsaw

CUTS more FOR less!
C-325NC

C-325NC is a high-standard bandsaw machine designed specifically for mass production. Featuring ductile cast iron vises, chrome plated feeding shaft, precision-ground heat-treated worm shafts, rub-free hardened wear plates, shaftless hydraulic motor driven chip auger, 5.7" touch panel, SNC-100 program control, and last but not least, precision feed pressure and feed rate dual valve system, C-325NC is an extremely powerful high performance bandsaw for your mass production needs.



Specification

Model		C-325NC
Capacity	Round	325 mm (12.8")
	Square	325 mm (12.8")
	Rectangular (WxH)	380x325 mm (15"x12.8")
Bundle Capacity	Width	190~300 mm
	Height	70~140 mm
Saw Blade	Speed	20~100 m/min (66~328fpm)
	Size (LxWxT)	3820x34x1.1 mm (150.4"x1.3"x0.042")
	Tension	Hydraulic (Automatic blade breakage detection)
	Motor Output	
	Saw blade	5HP (3.75 KW)
	Hydraulic	1HP (0.75 KW)
	Coolant	1/8 HP (0.1 KW)
Hydraulic Tank		35 L (9.2 gal.)
Coolant Tank		75 L (19.8 gal.)
Vise Control		Hydraulic
Automatic Indexing	Single	403 mm (15.9")
	Multiple	Max.9999 mm
Length	Rest Piece	50 mm (2")
Height of Work Bed		720 mm (28.3")
Gross Weight		1800 kgs
Floor Space		2045x2015x1345 mm (80.5"x79.3"x53")

* Due to continuous innovation and product development, designs and specifications are subject to change without notice and obligation.
* Photos shown may include optional accessories.



COSEN MACHINERY
http://www.cosen.com
E-Mail:info@cosen.com

